

FAG



FAG Special Spherical Roller Bearings for Vibratory Machinery

X-life quality

SCHAEFFLER GROUP
INDUSTRIAL

Contents

1	FAG spherical roller bearings for vibratory stresses	2
1.1	Operating conditions for bearings in vibratory machinery	2
1.2	Basic designs of FAG special spherical roller bearings	2
1.2.1	X-life spherical roller bearings 223...E1-T41A(D)	2
1.2.2	X-life spherical roller bearings 223...E1-JPA-T41A	2
1.3	Bearings with tapered bore	3
1.4	Bearings with coated bore	3
1.5	Specification T41A(T41D)	3
1.5.1	Tolerances for bearing bore and outside diameter	3
1.5.2	Radial internal clearance groups	4
1.5.3	Reduction in radial internal clearance of bearings with tapered bore	5
1.6	Permissible radial acceleration	6
1.7	Heat treatment	6
2	Specification of bearing size	6
2.1	Two bearing screen with circle throw	6
2.2	Two bearing screen with straight line motion	8
2.3	Eccentric screen	10
2.4	Nomogram for calculation of centrifugal force	11
2.5	Nomogram for calculation of basic load ratings	12
3	Design of bearing arrangements	13
3.1	Two bearing screen with circle throw (grease lubrication)	13
3.2	Two bearing screen with circle throw (oil sump lubrication)	14
3.3	Two bearing screen with circle throw (recirculating oil lubrication)	15
3.4	Two bearing screen with straight line motion (oil splash lubrication)	16
3.5	Four bearing screen (grease lubrication)	17
4	Lubrication of bearings	18
4.1	Grease lubrication	18
4.2	Oil lubrication	20
4.2.1	Oil sump lubrication	20
4.2.2	Recirculating oil lubrication	22
4.3	Recommended lubricants	22
5	Monitoring of vibrating screens	23
6	Dimension tables for FAG special spherical roller bearings for vibratory machinery	24
6.1	Series 223...E1-T41A(D)	24
6.2	Series 223...E1-JPA-T41A	25
7	Query for bearing calculation	26

FAG spherical roller bearings for vibratory stresses

Operating conditions · Basic designs of FAG special spherical roller bearings

1 FAG spherical roller bearings for vibratory stresses

1.1 Operating conditions for bearings in vibratory machinery

Vibratory screens used for grading (= separation of solid materials by grain size) of materials and other vibratory machinery such as road rollers and saw frames are among the machines subjected to the most severe stresses.

The rolling bearings in the exciter units of these machines must support not only high loads and high speeds but also accelerations and centrifugal forces.

Many of these applications involve adverse environmental conditions such as contamination and moisture.

The special spherical roller bearings developed by FAG are matched to the operating conditions in vibratory machinery and have proved highly successful in practical use.

In particular, the cages of the rolling bearings are subjected to stresses arising from high radial accelerations. In unfavourable cases, these may be overlaid by axial accelerations as well. The rotating imbalance generates rotating shaft deflection and additional sliding motion within the bearings. This increases the friction and therefore the operating temperature of the bearings. The special spherical roller bearings can support dynamic angular misalignments of up to 0,15°. If larger misalignments must be accommodated, please consult Schaeffler Group Industrial Application Engineering.

1.2 Basic designs of FAG special spherical roller bearings

FAG special spherical roller bearings for vibratory machinery have main dimensions corresponding to dimension series 23 (E DIN 616: 1995-01, ISO 15).

For the particular stresses occurring in vibratory machinery, we manufacture all the special spherical roller bearings described in this publication in accordance with specification T41A or T41D, see also section 1,5.

Very high load carrying capacity is achieved through optimum use of bearing cross-section as a result of further development of spherical roller bearings of series 223...-E1 of X-life quality. In the design for vibratory stresses, these bearings are supplied with bore diameters of up to 220 mm.

1.2.1 X-life spherical roller bearings 223...-E1-T41A(D)

FAG spherical roller bearings of the E1 design have an inner ring without a rib and are characterised by very high load carrying capacity. This advantage is also offered by FAG special bearings for vibratory stresses of design 223...-E1 with the suffix T41A or T41D, *Figure 1*. This is the new FAG standard design for bearings with a bore diameter of 40 up to and including 150 mm (bore code 08 to 30). After extensive testing, bearings of X-life quality 223...-E1-T41A(D) have proved extremely successful in numerous practical applications.

The bearing has one sheet steel window cage half per row of rollers with high geometrical stability. The cage halves are supported via the cage guide ring in the outer ring. The guide ring is of a single piece design. All cage parts are subjected to a special surface hardening process.

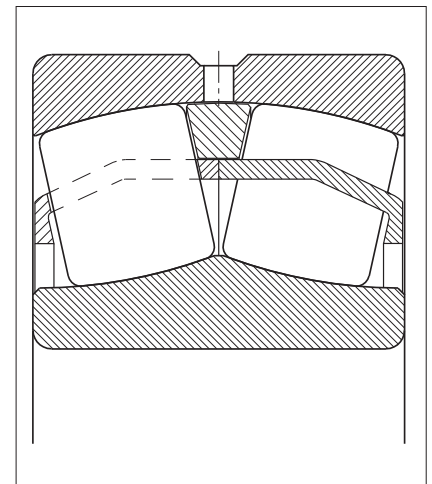

1: X-life-designs 223...-E1-T41A(D) and 223...-E1-JPA-T41A of special spherical roller bearings for vibratory machinery

1.2.2 X-life spherical roller bearings 223...-E1-JPA-T41A

Bearings with a bore diameter of 160 mm to 220 mm (bore code 32 to 44) are now also available in the design shown in *Figure 1*. These bearings also correspond to our proven X-life standard (see 1.2.1). The larger bearings can be identified by sheet steel cage JPA being indicated in the suffix.

FAG spherical roller bearings for vibratory stresses

Bearings with tapered bore · Bearings with coated bore · Specification T41A(T41D)

1.3 Bearings with tapered bore

In special cases such as saw frames, bearings are also available with a tapered bore (taper 1:12). The ordering designations are 223...-E1-K-T41A and 223...-E1-K-JPA-T41A with a bore diameter of ≥ 160 mm.

1.4 Bearings with coated bore

In order to reduce or prevent fretting corrosion between the bearing bore and the shaft, we can for specific orders supply spherical roller bearings with a cylindrical bore, coated with Durotect® CK. This ensures that the possibility of displacement (non-locating bearing function) between the bearing bore and shaft in response to thermal influences is maintained over and beyond a long period of operation. The bearings with a coated bore correspond in their dimensions and tolerances to and are interchangeable with the FAG standard bearings for vibratory machinery. For bearings 22317-E1-T41D to 22330-E1-T41D, the cylindrical bore coated with Durotect® CK is standard. For further information on this matter, please see our publication PPD, FAG Special spherical roller bearings with Durotect® CK plating in the bore. For bearings outside this bearing bore size range, suffix J24BA must be indicated in the ordering designation for a coated inner ring bore. Ordering example for a bearing with a Durotect® CK coated bore within the standard range: 22320-E1-T41D.

Ordering example for a bearing with a Durotect® CK coated bore outside the standard range: 22316-E1-J24BA-T41A.

1.5 Specification T41A(T41D)

FAG spherical roller bearings for vibratory machinery are manufactured in accordance with the specification T41A or T41D. This takes into consideration the particular requirements of the application. The specification defines, for example, the tolerances of bore and outside diameter, as well as the radial internal clearance of the bearings. The other tolerances are in accordance with tolerance class PN to DIN 620.

1.5.1 Tolerances for bearing bore and outside diameter

Specification T41A(D) prescribes a bore tolerance in the upper half of the normal tolerance zone. For the outside diameter, only the centre half of the normal tolerance zone is permissible. In bearings with a tapered bore, the reduced tolerance range applies to the outside diameter only. Tolerance values see table, *Figure 2*. Through these measures, the sliding fit required for the inner ring is reliably achieved with shaft tolerances g6 or f6 and the interference fit required for the outer ring is reliably achieved with housing tolerance P6. For bearings with a coated bore, we recommend a shaft tolerance f6. The inner ring does not have pure point load and the outer ring is subjected to circumferential load. Geometrical tolerances of bearing seating surfaces, see page 4.

2: Restricted tolerance according to specification T41A(D)

Inner ring

Nominal bearing bore diameter	over incl.	Dimensions in mm					
		30	50	80	120	180	250
		50	80	120	180	250	315
		Tolerances in μm					
Deviation Δ_{dmp}		0	0	0	0	0	0
		-7	-9	-12	-15	-18	-21

Outer ring

Nominal outside diameter	over incl.	Dimensions in mm					
		80	150	180	315	400	500
		150	180	315	400	500	630
		Tolerances in μm					
Deviation Δ_{Dmp}		-5	-5	-10	-13	-13	-15
		-13	-18	-23	-28	-30	-35

FAG spherical roller bearings for vibratory stresses

Specification T41A(T41D)

Geometrical tolerances of bearing seating surfaces

In order to achieve the required fit, the bearing seats and fit surfaces of the shaft and housing bore must conform to certain tolerances, see the following table.

Bearing seating surface area	Diameter tolerance	Roundness tolerance	Parallelism tolerance	Runout tolerance of abutting shoulder
Shaft	IT6 (IT5)	Circumferential load IT4/2	IT4	IT4
		Point load IT5/2	IT5	
Housing	IT7 (IT6)	Circumferential load IT5/2	IT5	IT5
		Point load IT6/2	IT6	

1.5.2 Radial internal clearance groups

Specification T41A(D) prescribes C4 as the standard internal clearance group for all spherical roller bearings of vibrating screen design so it is not necessary to state this explicitly. Radial preloading of the bearings is thus prevented in the event of unfavourable interaction between different influences such as fits, deformations, etc. This applies especially during startup and running-in, when the largest temperature differences occur between the inner and outer ring. It is only necessary to consider a special radial internal clearance for spherical roller bearings in vibratory machinery in rare cases, for example if the material to be screened is hot or the bearing arrangement is subjected to excessive external heat.

In special cases such as saw frames, bearings with an internal clearance other than C4 may be necessary. The suffix for the radial internal clearance, e. g. C3, must then be stated explicitly. Bearings in this variant are available by agreement. For radial internal clearance values of special spherical roller bearings, see table, *Figure 3*.

3: Radial internal clearance of FAG spherical roller bearings

Nominal bearing bore diameter	Dimensions in mm														
	over	30	40	50	65	80	100	120	140	160	180	200	225	250	280
	incl.	40	50	65	80	100	120	140	160	180	200	225	250	280	315

With cylindrical bore

Internal clearance in μm

Internal clearance group	min.	45	55	65	80	100	120	145	170	180	200	220	240	260	280
C3	max.	60	75	90	110	135	160	190	220	240	260	290	320	350	370

Internal clearance group	min.	60	75	90	110	135	160	190	220	240	260	290	320	350	370
C4	max.	80	100	120	145	180	210	240	280	310	340	380	420	460	500

With tapered bore

Internal clearance in μm

Internal clearance group	min.	50	60	75	95	110	135	160	180	200	220	250	270	300	330
C3	max.	65	80	95	120	140	170	200	230	260	290	320	350	390	430

Internal clearance group	min.	65	80	95	120	140	170	200	230	260	290	320	350	390	430
C4	max.	85	100	120	150	180	220	260	300	340	370	410	450	490	540

FAG spherical roller bearings for vibratory stresses

Specification T41A(T41D)

1.5.3 Reduction in radial internal clearance of bearings with tapered bore

Bearings with a tapered bore are mounted on a conical shaft seat or, using a sleeve, on a cylindrical shaft. The reduction in the radial internal clearance during mounting (see table, *Figure 4*) can be taken as an indication of the seating between the inner ring and shaft.

4: Reduction in radial internal clearance in mounting of spherical roller bearings with tapered bore (solid shaft)

Nominal bore diameter		Reduction in radial internal clearance		Displacement on taper 1:12				Control value for minimum radial internal clearance after mounting		
d over mm	incl.	min. mm	max.	Shaft min. mm	max.	Sleeve min.	max.	CN min. mm	C3 min.	C4 min.
30	40	0,02	0,025	0,35	0,4	0,35	0,45	0,015	0,025	0,04
40	50	0,025	0,03	0,4	0,45	0,45	0,5	0,02	0,03	0,05
50	65	0,03	0,04	0,45	0,6	0,5	0,7	0,025	0,035	0,055
65	80	0,04	0,05	0,6	0,75	0,7	0,85	0,025	0,04	0,07
80	100	0,045	0,06	0,7	0,9	0,75	1	0,035	0,05	0,08
100	120	0,05	0,07	0,7	1,1	0,8	1,2	0,05	0,065	0,1
120	140	0,065	0,09	1,1	1,4	1,2	1,5	0,055	0,08	0,11
140	160	0,075	0,1	1,2	1,6	1,3	1,7	0,055	0,09	0,13
160	180	0,08	0,11	1,3	1,7	1,4	1,9	0,06	0,1	0,15
180	200	0,09	0,13	1,4	2	1,5	2,2	0,07	0,1	0,16
200	225	0,1	0,14	1,6	2,2	1,7	2,4	0,08	0,12	0,18
225	250	0,11	0,15	1,7	2,4	1,8	2,6	0,09	0,13	0,2
250	280	0,12	0,17	1,9	2,6	2	2,9	0,1	0,14	0,22
280	315	0,13	0,19	2	3	2,2	3,2	0,11	0,15	0,24

FAG spherical roller bearings for vibratory stresses

Specification of bearing size

1.6 Permissible radial acceleration

Since the centrifugal forces are supported against the outer ring, high acceleration forces are possible in special spherical roller bearings for vibratory machinery, see diagram below.

Permissible radial acceleration values of special spherical roller bearings (for dimension series 223 and 233)

- a) $n \cdot d_m = 350\,000 \text{ min}^{-1} \cdot \text{mm}$
Maximum possible values with optimum mounting conditions and oil lubrication, e. g. planetary gearbox
- b) $n \cdot d_m = 140\,000 \text{ min}^{-1} \cdot \text{mm}$
Normal operating conditions for saw frames with grease lubrication
- c) $n \cdot d_m = 230\,000 \text{ min}^{-1} \cdot \text{mm}$ to $300\,000 \text{ min}^{-1} \cdot \text{mm}$
Normal use for vibrating screens with grease or oil lubrication

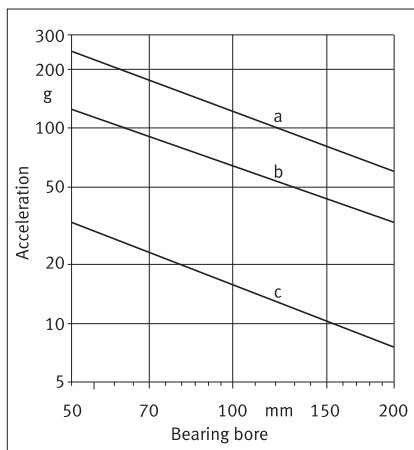

1.7 Heat treatment

All FAG spherical roller bearings of series 223...-E1-T41A(D) and 223...-E1-JPA-T41A for vibratory stresses are heat treated such that they are dimensionally stable up to an operating temperature of 200 °C.

2 Specification of bearing size

Vibrating screen bearings are normally designed for a basic rating life L_h of between 10 000 and 20 000 hours.

Note:

$$L_h = (C/P)^p \cdot 10^6 / (n \cdot 60) \text{ [h]}$$

C Basic dynamic load rating [kN], see bearing tables, section 5

P Equivalent dynamic load [kN], see sections 2.1 to 2.3

p = 3,33 Life exponent for roller bearings

n Speed [min^{-1}]

When determining the equivalent dynamic load P of spherical roller bearings for vibrating applications, the influences that cannot be precisely defined are taken into consideration by means of a safety factor f_z of 1,2 times the radial bearing load F_r . Based on practical experience, this gives sufficiently long running times.

More precise calculation can be achieved using the expanded adjusted rating life L_{hnm} to ISO 281 (see also Catalogue HR 1, Rolling Bearings). The fatigue limit load C_{ur} required in this case is stated in the dimension tables.

2.1 Two bearing screen with circle throw

Figure 5 shows a schematic of an imbalance-type two bearing screen. The bearing load imposed by the centrifugal force of the screen box is derived from the mass of the screen box, the vibration radius and the speed in accordance with the following formula:

$$F_r = \frac{1}{z} \cdot \frac{m}{10^3} \cdot r \cdot \omega^2 =$$

$$= \frac{1}{z} \cdot \frac{G}{g} \cdot r \left(\frac{\pi \cdot n}{30} \right)^2 \text{ [kN]} \quad (1)$$

F_r Radial bearing load [kN]

m Mass of screen box [kg]

r Vibration radius [m]

ω Angular velocity [1/s]

G Weight of screen box [kN]

g Acceleration due to gravity [9,81 m/s^2]

n Speed [min^{-1}]

z Number of bearings

The vibration radius r in two bearing screens can be determined from the ratio of the screen box weight to the exciter weight. Since two bearing screens generally operate in a supercritical range approaching the static amplitude, it can be assumed that the common centroidal axis of the two masses (screen box and exciter) is maintained during rotation, Figure 6.

Based on this precondition:

$$G \cdot r = G_1 (R - r)$$

The vibration radius is thus

$$r = \frac{G_1 \cdot R}{G + G_1} \text{ [m]} \quad (2)$$

where

G Weight of screen box [kN]

G_1 Weight of exciter [kN]

R Distance between centre of gravity of exciter and bearing axis [m]

r Vibration radius of screen box [m]

$G_1 \cdot R$ Imbalance moment of exciter [kN m]

$G + G_1$ Total weight supported by springs [kN]

Specification of bearing size

Two bearing screen with circle throw

If (2) is incorporated in (1) and the expression is transformed, the radial bearing load is

$$F_r = \frac{1}{z} \cdot \frac{G_1}{g} \cdot \frac{R}{1 + \frac{G_1}{G}} \cdot \left(\frac{\pi \cdot n}{30} \right)^2 \text{ [kN]} \quad (3)$$

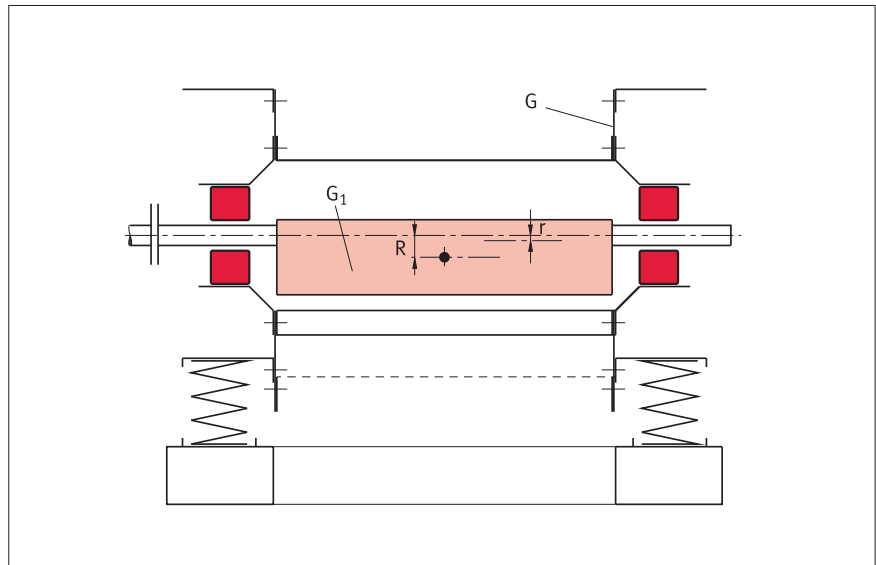

5: Schematic of two bearing screen with circle throw

Example

Weight of screen box $G = 35 \text{ kN}$

Vibration radius $r = 0,003 \text{ m}$

Speed $n = 1200 \text{ min}^{-1}$

Number of bearings $z = 2$

Bearing load according to formula (1)

$$F_r = \frac{1}{2} \cdot \frac{35}{9,81} \cdot 0,003 \left(\frac{\pi \cdot 1200}{30} \right)^2 = 84,5 \text{ [kN]}$$

The equivalent dynamic bearing load required in order to determine the necessary basic dynamic load rating of the bearing is then

$$P = 1,2 \cdot F_r = 1,2 \cdot 84,5 = 101 \text{ [kN]}$$

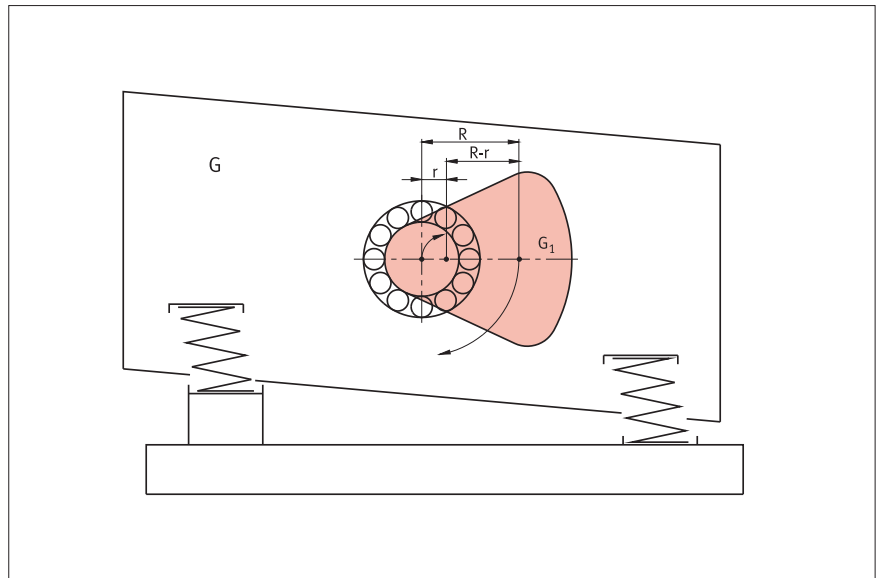

6: The vibration radius is determined by the ratio of the screen box weight to the exciter weight

Specification of bearing size

Two bearing screen with straight line motion

2.2 Two bearing screen with straight line motion

In principle, the exciter in a two bearing screen with straight line motion comprises two contra-rotating synchronous circular throw systems, *Figure 7*.

The forces are determined by resolving the rotating centrifugal force vectors of the imbalance shafts into two components, in the direction of the line connecting the two shafts and the direction perpendicular to this line. It can be seen that the components lying in the direction of the connecting line cancel each other out, whereas the perpendicular components add up, generating a harmonic pulsating inertia force that induces straight line vibration of the screen box. Since the so-called static amplitude is induced in the direction of vibration due to the supercritical operation and the common centroidal axis of the screen box and the imbalance masses does not vary during vibration, the bearing loads are as follows: In the direction of vibration

$$F_{r \min} = \frac{1}{z} \cdot \frac{m}{10^3} \cdot r \cdot \omega^2 =$$

$$= \frac{1}{z} \cdot \frac{G}{g} \cdot r \cdot \left(\frac{\pi \cdot n}{30}\right)^2 =$$

$$= \frac{1}{z} \cdot \frac{G_1}{g} \cdot (R - r) \cdot \left(\frac{\pi \cdot n}{30}\right)^2 \quad [\text{kN}] \quad (4)$$

where

r [m] Vibration radius

R [m] Distance between the centres of gravity of the exciters and the corresponding bearing axes

Perpendicular to the direction of vibration

$$F_{r \max} = \frac{1}{z} \cdot \frac{G_1}{g} \cdot R \cdot \left(\frac{\pi \cdot n}{30}\right)^2 \quad [\text{kN}] \quad (5)$$

giving a somewhat larger bearing load.

In contrast to a circle throw screen, in which the bearing load is constant, the bearing load in a straight line screen alternates twice during one revolution of the exciter shafts between $F_{r \max}$ and $F_{r \min}$.

If formula (4) is compared with formula (1), it can be seen that the minimum bearing load of a screen with straight line motion is exactly the same as the bearing load of a comparable circle throw screen. For a straight line screen with a load varying according to a sinusoidal function, the bearing load can be determined according to the formula

$$F_r = 0,68 \cdot F_{r \max} + 0,32 \cdot F_{r \min} \quad [\text{kN}]$$

Whereas the bearing load in a circle throw screen can be determined simply from data for the screen box G, vibration radius r and speed n, these data only allow calculation of the minimum load in a straight line screen. For more precise calculation, it is also necessary to know either the exciter mass G_1 or the distance R between the centres of gravity of the exciters from their bearing axes. It is then possible using

$$G \cdot r = G_1 (R - r) \quad [\text{kN m}]$$

to determine the unknown quantity.

Example

Weight of screen box $G = 33 \text{ kN}$

Weight of exciter $G_1 = 7,5 \text{ kN}$

Vibration radius $r = 0,008 \text{ m}$

Speed $n = 900 \text{ min}^{-1}$

Number of bearings $z = 4$

$$\text{With } R = \frac{r(G + G_1)}{G_1}$$

$$= \frac{0,008(33 + 7,5)}{7,5} = 0,0432 \quad [\text{m}]$$

this gives, according to (4) and (5)

$$F_{r \min} = \frac{1}{4} \cdot \frac{33}{9,81} \cdot 0,008 \cdot \left(\frac{\pi \cdot 900}{30}\right)^2$$

$$= 59,8 \quad [\text{kN}]$$

$$F_{r \max} = \frac{1}{4} \cdot \frac{7,5}{9,81} \cdot 0,0432 \cdot \left(\frac{\pi \cdot 900}{30}\right)^2$$

$$= 73,3 \quad [\text{kN}]$$

Bearing load

$$F_r = 0,68 \cdot 73,3 + 0,32 \cdot 59,8 =$$

$$= 69 \quad [\text{kN}]$$

The equivalent dynamic bearing load required in order to determine the necessary basic dynamic load rating of the bearing is then

$$P = 1,2 \cdot 69 = 83 \quad [\text{kN}]$$

Specification of bearing size

Two bearing screen with straight line motion

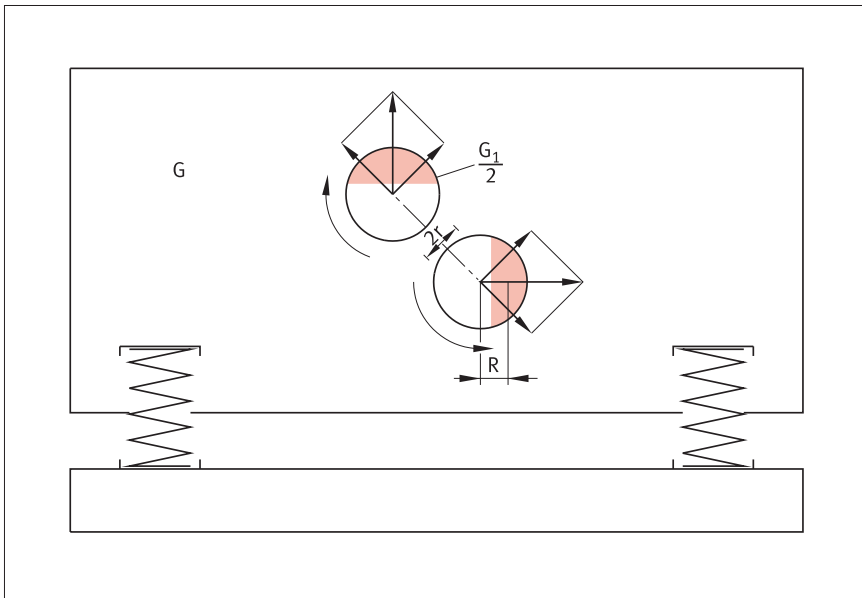

7: Schematic of two bearing screen with straight line motion

Specification of bearing size

Eccentric screen

2.3 Eccentric screen

In contrast to a two bearing screen, the vibration radius of an eccentric screen is a function of the eccentricity of the shaft.

The bearing for the two inner rings is determined using the same formula as for the circle throw screen

$$F_r = \frac{1}{z} \cdot \frac{G}{g} \cdot r \cdot \left(\frac{\pi \cdot n}{30}\right)^2 \text{ [kN]} \quad (1)$$

where r is the eccentric radius of the crankshaft and z is the number of inner bearings, *Figure 8*. The influence of the support springs on the loading of the inner bearings can be regarded as negligible.

The outer bearings of the eccentric screen are only lightly loaded since the centrifugal force of the screen box during idling is compensated by counterweights (G_2). The load on these bearings is not constant; it varies according to a sinusoidal pattern due to the support springs on the screen box. In operation, the material in the box interferes with the balanced condition of the machine. This places additional load on the outer bearings.

However, this additional load is very small.

The selection of bearings is based on the shaft diameter. This results in bearings whose load carrying capacity is so high that a fatigue life calculation is unnecessary. Since these bearings do not undergo vibration, spherical roller bearings of the standard design are sufficient.

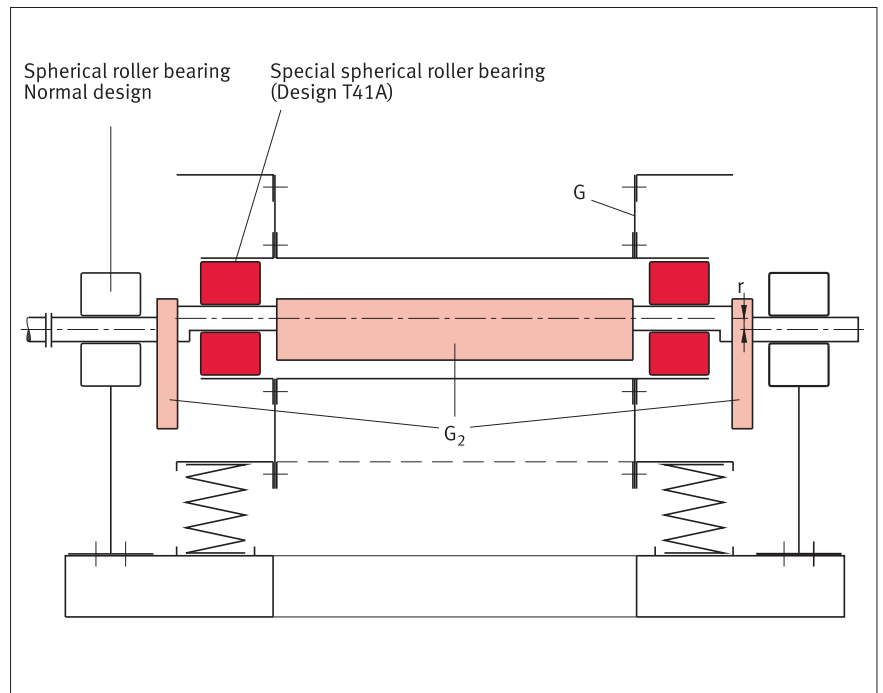

8: Schematic of an eccentric screen

Example

Weight of screen box $G = 60 \text{ kN}$
 Eccentric radius $r = 0,005 \text{ m}$
 Speed $n = 850 \text{ min}^{-1}$
 Number of bearings $z = 2$
 Inner bearings: Bearing load according to formula (1)

The equivalent dynamic bearing load required in order to determine the necessary basic dynamic load rating of the bearing is then
 $P = 1,2 \cdot 121 = 145 \text{ [kN]}$

$$F_r = \frac{1}{2} \cdot \frac{60}{9,81} \cdot 0,005 \cdot \left(\frac{\pi \cdot 850}{30}\right)^2 = 121 \text{ [kN]}$$

Specification of bearing size

Nomogram for calculation of centrifugal force

2.4 Nomogram for calculation of centrifugal force of the imbalance masses or the centrifugal force of the screen box mass

F_{max} , F_{min} and F are centrifugal forces [kN]
 n is the speed [min⁻¹]
 r is the vibration radius [m]
 R is the distance between the centre of gravity of the exciter and the bearing axis [m]

b is the acceleration [m/s²]
 G is the weight of the screen box [kN]
 G_1 is the weight of the imbalance mass [kN]
 $g = 9,81$ is the acceleration due to gravity [m/s²]

$$F_{max} = \frac{G_1}{g} \cdot R \cdot \left(\frac{\pi \cdot n}{30}\right)^2 \quad [\text{kN}]$$

$$F_{min} = \frac{G_1}{g} \cdot (R - r) \cdot \left(\frac{\pi \cdot n}{30}\right)^2 \quad [\text{kN}]$$

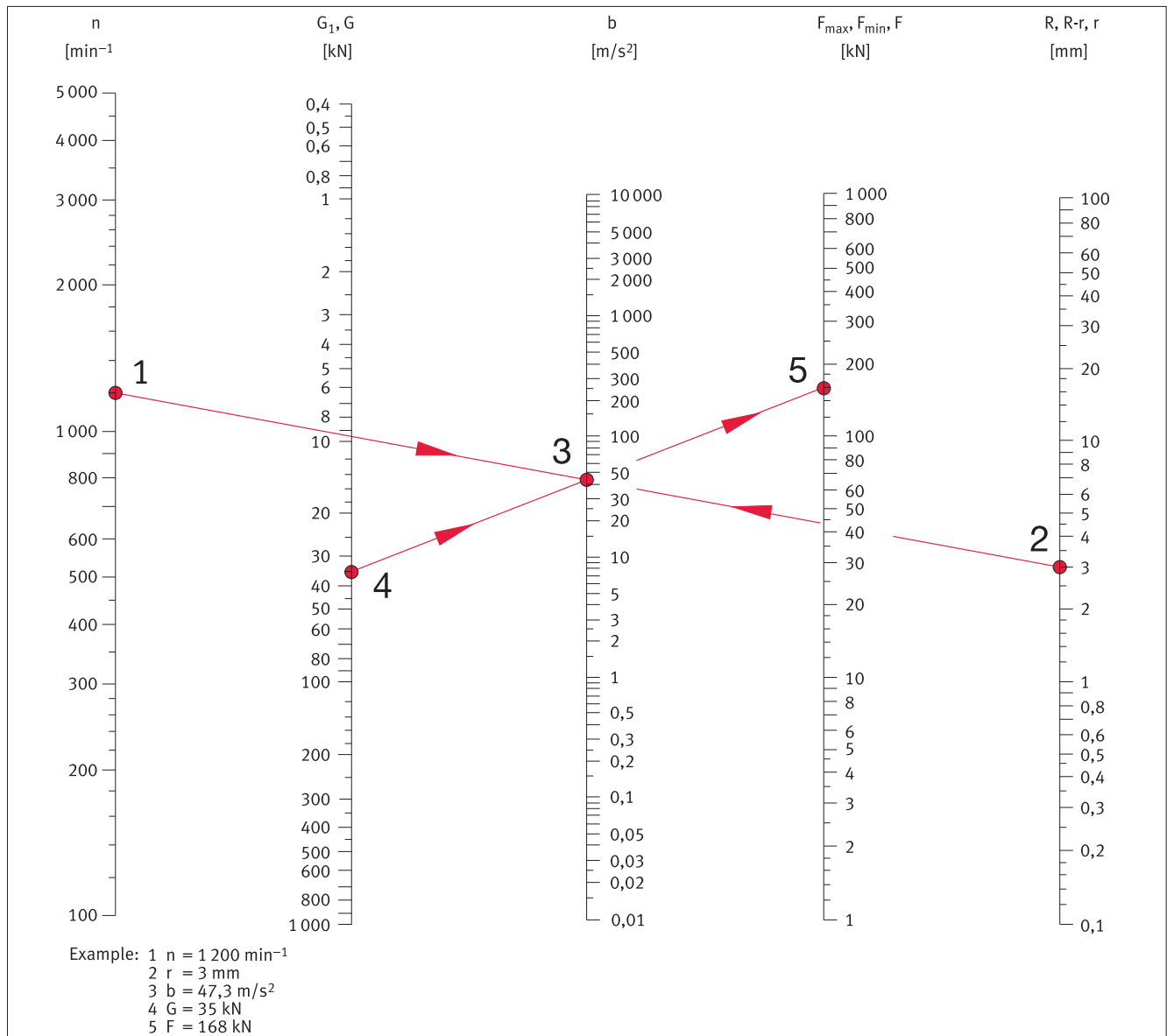
$$F = \frac{G}{g} \cdot r \cdot \left(\frac{\pi \cdot n}{30}\right)^2 \quad [\text{kN}]$$

Specification of bearing size

Nomogram for calculation of basic load ratings

2.5 Nomogram for calculation of basic dynamic load rating required

The following are required in order to calculate the basic dynamic load rating C [kN]:

- n Speed [min⁻¹]
- L_h Basic rating life [h]
- P Equivalent dynamic load [kN]

In two bearing screens with circle throw and inner bearings with eccentric screens

$$P = 1,2 \cdot \frac{F}{z} \quad [\text{kN}]$$

In two bearing screens with straight line motion

$$P = 1,2 \cdot \left(\frac{0,68 \cdot F_{\max} + 0,32 \cdot F_{\min}}{z} \right)$$

where 1,2 is the safety factor
z is the number of bearings
F is the centrifugal force according to nomogram 1 (section 2.4)

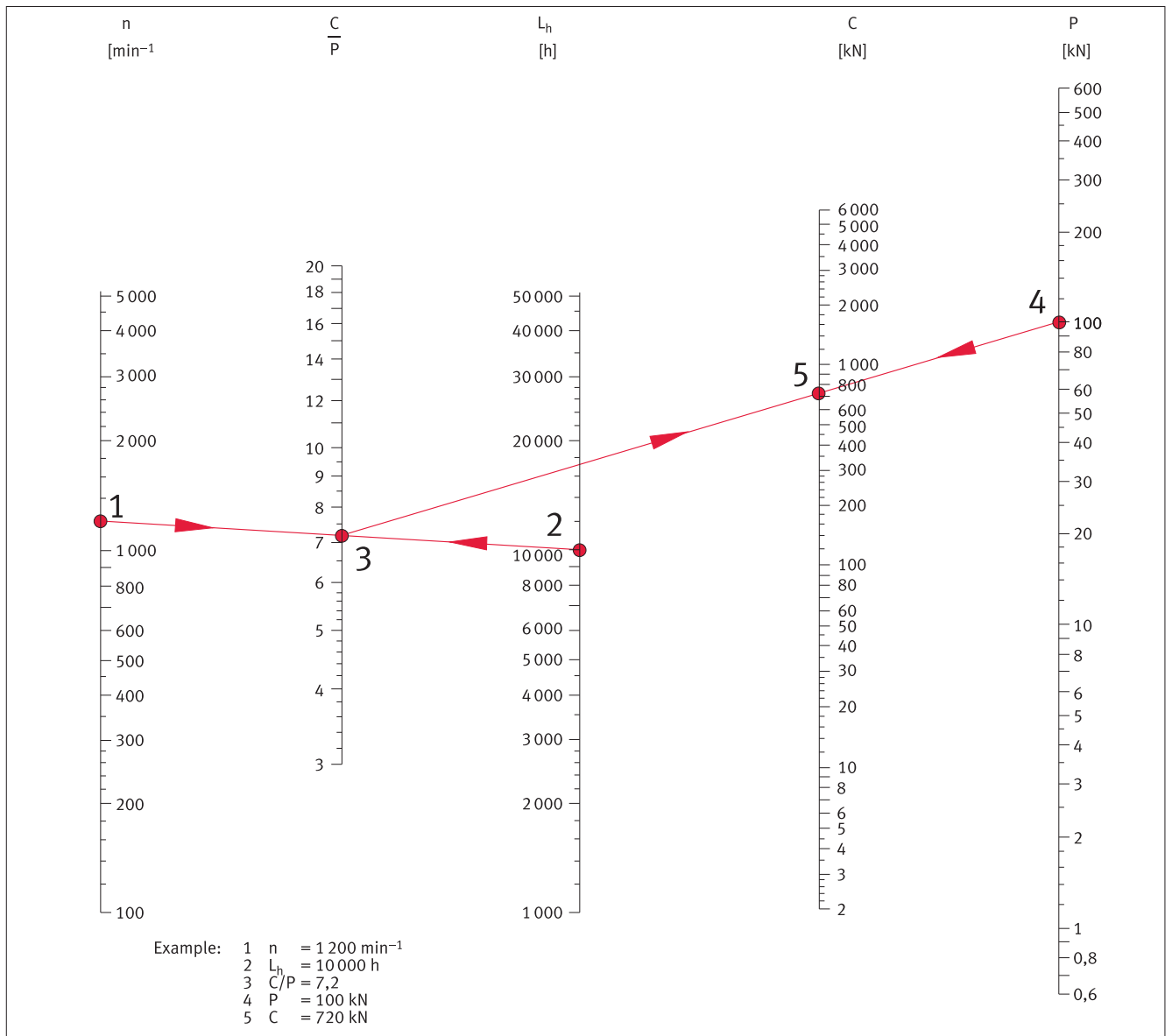

Design of bearing arrangements

Two bearing screen with circle throw (grease lubrication)

3 Design of bearing arrangements

3.1 Two bearing screen with circle throw (grease lubrication)

Figure 9 shows the essential bearing arrangement design of a two bearing screen with circle throw and grease lubrication. The imbalance shaft is supported in two special spherical roller bearings FAG 223..-E1-T41A. The bearing on the drive side is fitted as a locating bearing while the opposing bearing is a non-locating bearing.

Fitting and dismantling of bearings

After inspection of the adjacent parts, the bearing is then mounted in the housing bore. Smaller bearings can be pressed in while cold. For larger bearings, the housing is heated uniformly to the point where the interference between the bearing outer ring and housing bore is eliminated. As the housing cools down, the interference fit is achieved. The bearing and housing are then slid onto the shaft. For dismantling, it is easier to press the bearing out of the housing if the guard tube flange (part A in Figure 9) is replaced by a screw mounted ring equipped with several extraction screws.

Lubrication and sealing

A favourable option is to feed the grease as shown here via the circumferential groove and the lubrication holes in the bearing

outer ring. In this way, the fresh grease is fed directly to the rolling and sliding surfaces of the rolling bearing, ensuring uniform lubrication of both rows of rollers. The fresh grease displaces the old, possibly contaminated grease from the interior of the bearing. On the inner side of the bearing arrangement, the old grease escapes via the gap in the grease

baffle and collects in the guard tube. On the outer side, it collects at the grease collector pocket, from which it is periodically removed. The bearing is sealed against external influences by a labyrinth that can be relubricated and whose sealing action can be further increased by a V ring on the innermost labyrinth passage.

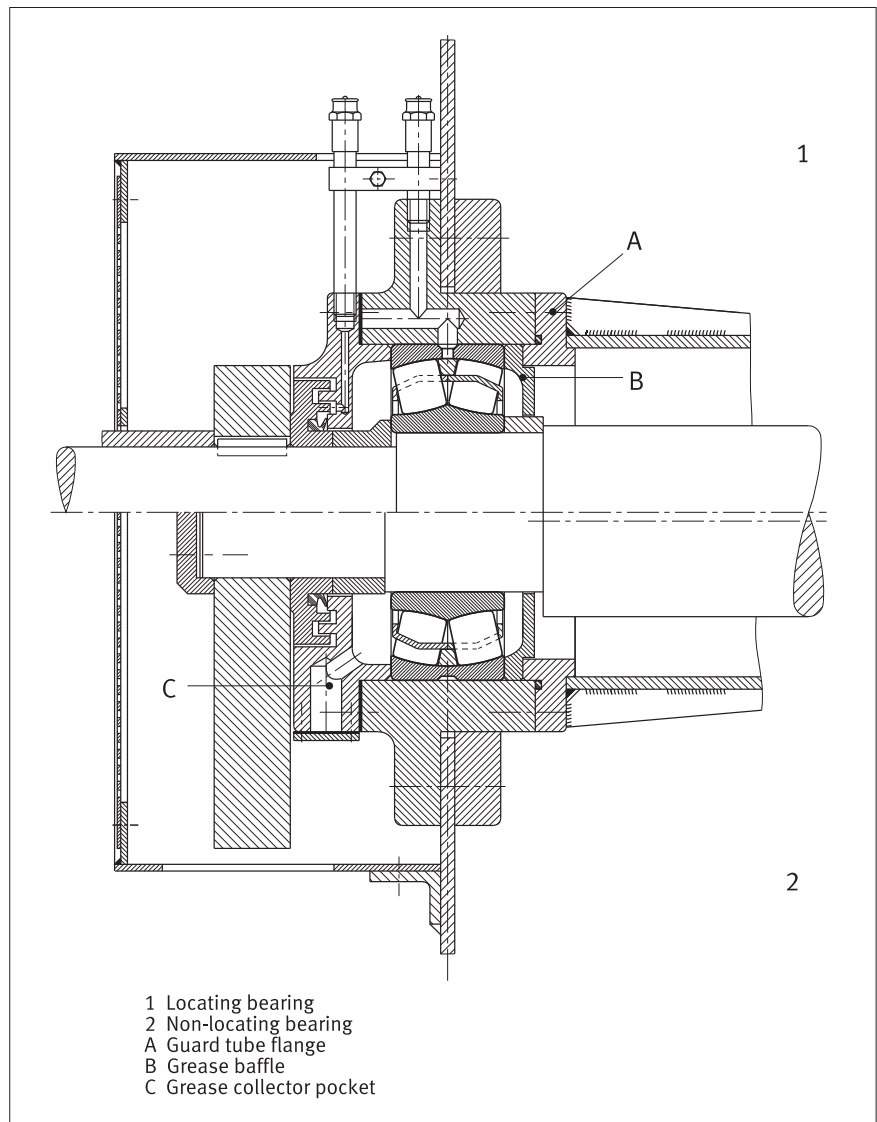

9: Two bearing screen with circle throw (grease lubrication)

Design of bearing arrangements

Two bearing screen with circle throw (oil sump lubrication)

3.2 Two bearing screen with circle throw (oil sump lubrication)

Figure 10 shows the essential bearing arrangement design of a two bearing screen with circle throw and oil sump lubrication. Sealing against entry of external contamination is provided by a grease-filled labyrinth that can be relubricated. A splash ring with a oil collector groove prevents egress of oil. On the bearing side, the sealing area is shielded by a flinger ring.

In order to prevent the grease in the labyrinth entering the oil cavities, a V ring is fitted between the labyrinth and splash ring. The connecting hole in the lower section of the housing equalises the oil sump level between the two sides of the bearing. The oil level should be such that the lowest roller in the bearing is immersed to approximately half its diameter in oil when the bearing is stationary. At this level, there is an overflow hole that is closed off after the housing is filled. The oil outlet screw contains a small permanent magnet that draws wear particles out of the oil. The oil quantity should be as large as possible so that the oil does not need to be changed too frequently. In general, the shaft guard tube is used as an additional oil reservoir.

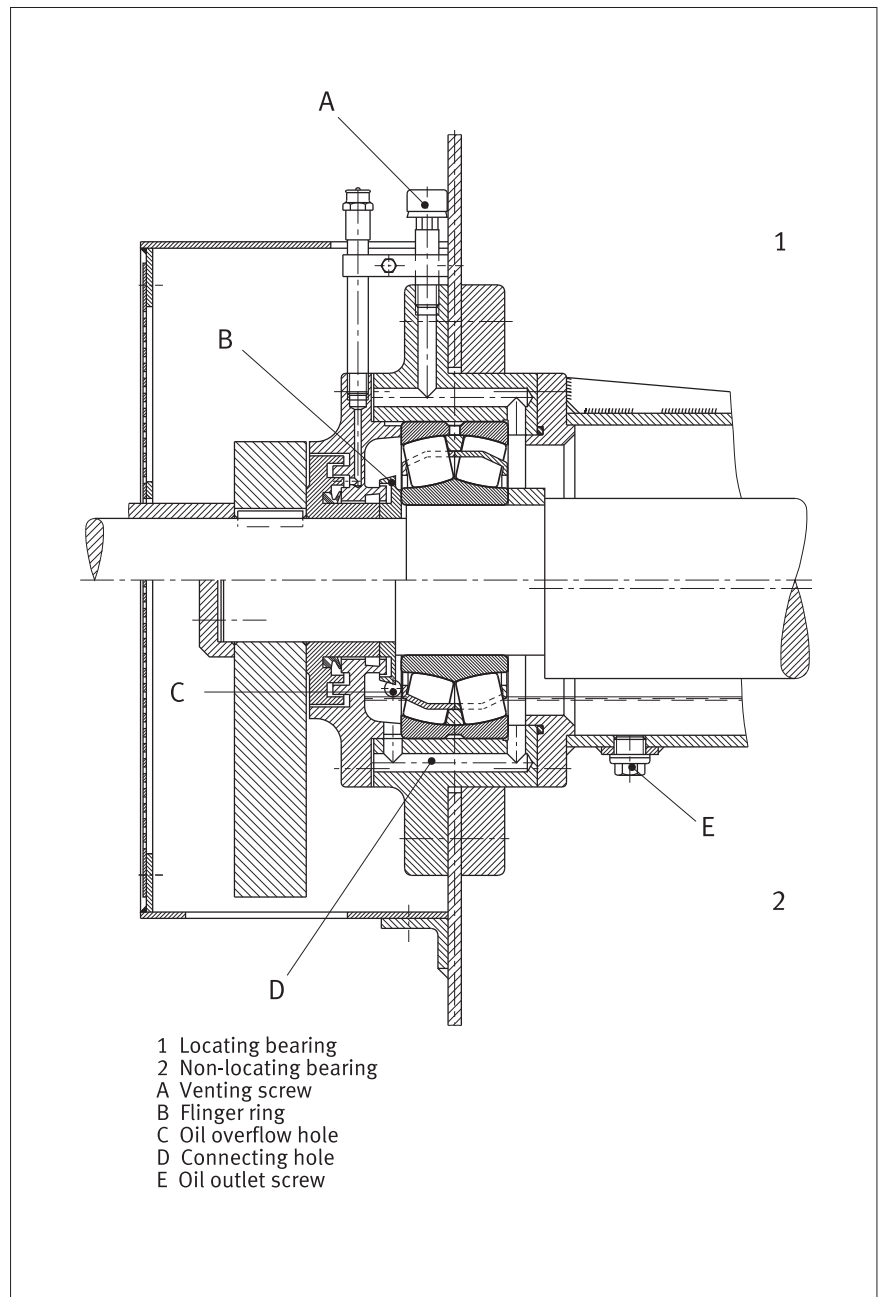

10: Two bearing screen with circle throw (oil sump lubrication)

Design of bearing arrangements

Two bearing screen with circle throw (recirculating oil lubrication)

3.3 Two bearing screen with circle throw (recirculating oil lubrication)

The design of the bearing arrangement with recirculating oil lubrication shown in *Figure 11* is similar to that of the bearing arrangement with oil sump lubrication (see section 3.2). The connecting hole in the lower section of the housing equalises the oil level between the two sides of the bearing.

The sealing arrangement is taken from the oil sump lubrication. The oil outlet hole is located at such a level that, even if the oil feed is interrupted, there is still an emergency oil reserve available. The oil is fed via the lubrication groove and lubrication holes in the bearing outer ring. Oil filtration is absolutely essential (cf. section 4.2.2).

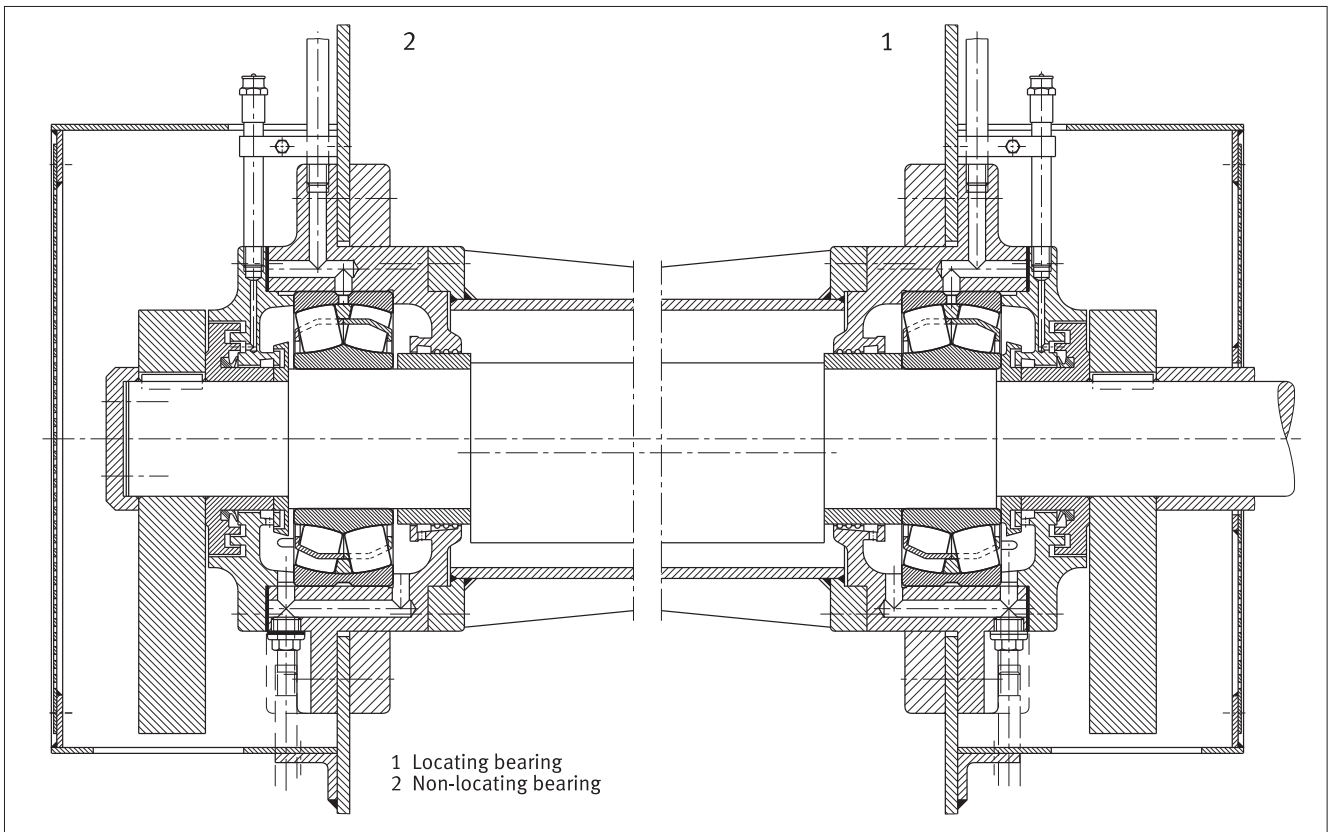

11: Two bearing screen with circle throw (recirculating oil lubrication)

Design of bearing arrangements

Two bearing screen with straight line motion (oil splash lubrication)

3.4 Two bearing screen with straight line motion (oil splash lubrication)

Figure 12 shows the bearing arrangement of an exciter for a two bearing screen with straight line motion. The two contra-rotating, synchronously geared imbalance shafts are fitted with FAG special spherical roller bearings 223.-E1-T41A. The bearings on the

gear side are fitted as locating bearings in order to prevent disruption to the gear cycling behaviour if length variations occur (temperature differences). The bearings are lubricated by the oil thrown off by the gears and a flinger shield. Baffle plates on the lower halves of the housing end faces ensure that the oil level reaches approximately the centre of the lowest roller in the bearings.

The passage for the drive shaft is equipped with a splash ring seal and, in order to prevent ingress of contamination, with a labyrinth. A V ring can also be fitted between the labyrinth and splash ring. The oil level is just high enough that the lower gear and flinger shield are immersed in the oil sump. The oil level is monitored by lateral oil level indicators.

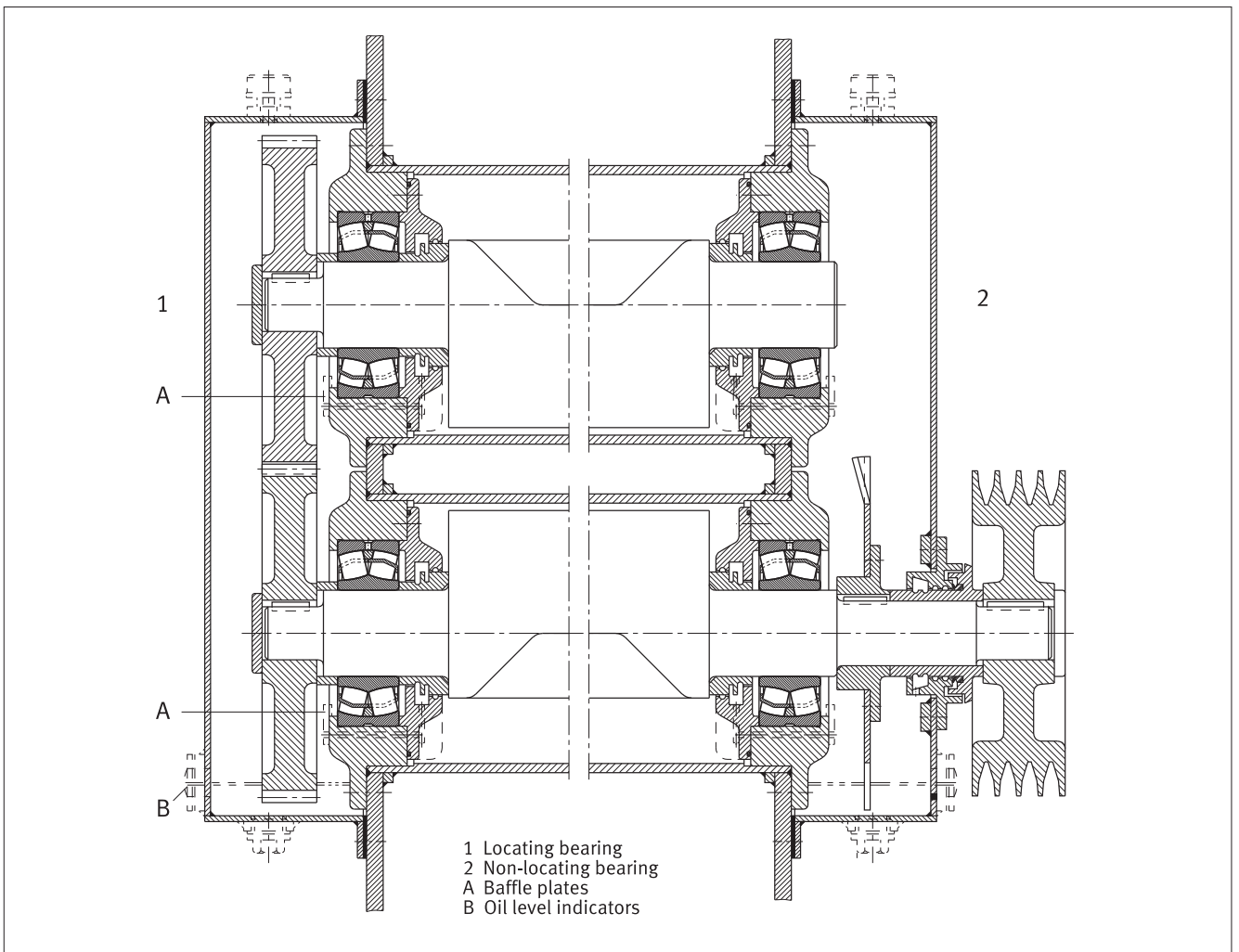

12: Two bearing screen with straight line motion (oil splash lubrication)

Design of bearing arrangements

Four bearing screen (grease lubrication)

3.5 Four bearing screen (grease lubrication)

Figure 13 shows the eccentric shaft of a four bearing screen. Since the stresses acting on the inner bearings are comparable with those acting on the bearings of a two bearing screen, these positions are fitted with FAG special spherical roller bearings of series 223..-E1-T41A. Although the interaction of the rotating screen box centrifugal force and the directionally constant spring forces does not give a pure point load on the inner ring, the fits selected are generally the same as for the two bearing screen. The outer rings have a P6 fit in the housing, while the inner rings have an f6 or g6 fit on the shaft. One of the two inner bearings is fitted as a locating bearing, while the other is a non-locating bearing with an inner ring that can be displaced along the shaft. In all other respects, the design of the inner bearing arrangement shown is identical to the bearing arrangement for a two bearing screen with grease lubrication. Conditions are different in the outer bearings. In order to ensure that, if possible, imbalance forces are not transmitted to the foundations and the bearing load remains low, the imbalance moment of the screen box in the eccentric screen is compensated by means of counterweights. During idling, the outer bearings are only subjected to the forces exerted by the support springs. The support springs are preloaded to such an extent that the outer bearings are subjected to a sinusoidally pulsating but directionally constant radial load.

Although the precisely balanced condition is disrupted during operation by the material in the box – the spring forces are overlaid by an uncompensated rotating centrifugal force – and the load direction may therefore vary within a certain angle, the bearing fits are determined on the assumption that the outer ring is subjected to point load. A loose fit must therefore be selected for the outer rings in the housing bore. The inner rings are normally located on the shaft – as shown – using withdrawal sleeves. The bearing on the drive side is fitted as a locating bearing while the opposing bearing is a

non-locating bearing with an outer ring capable of axial displacement.

Normal machining tolerances that have proved effective for the outer bearing seats are

Shaft: h8/h9
(Shaft tolerances for location by withdrawal sleeve)

Housing: H7

Since the outer bearings do not undergo translation movement and are only subject to light loads, normal spherical roller bearings with a tapered bore and normal internal clearance can be selected.

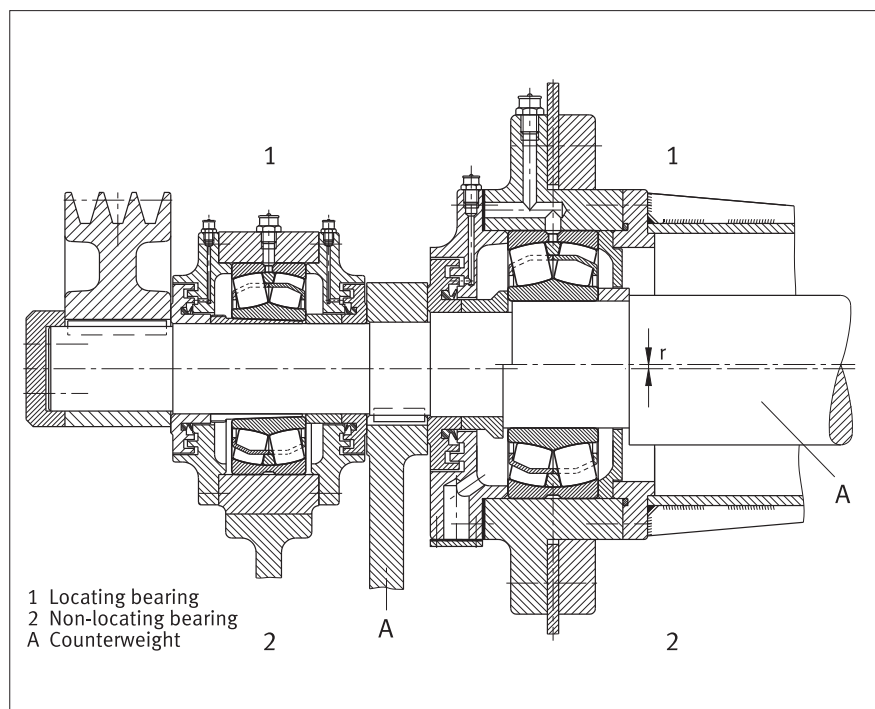

13: Four bearing screen (grease lubrication)

Lubrication of bearings

Grease lubrication

4 Lubrication of bearings

Spherical roller bearings in vibratory machinery are subjected to very high operating loads and adverse environmental conditions.

The lubricant type, lubrication method and lubricant supply must be carefully selected and matched in order to fulfil the requirements for functional suitability and service life of the vibratory machinery bearings.

Depending on the operating conditions, bearing size and particular requirements of the plant operator, lubrication using grease or oil can be selected.

4.1 Grease lubrication

In most vibratory machinery, the special spherical roller bearings are lubricated using grease.

Grease lubrication is normally used up to a speed parameter

$$n \cdot d_m = 300\,000 \text{ min}^{-1} \cdot \text{mm}$$

(n = operating, d_m = mean bearing diameter). Only greases that have been tested and proven should be used, see section 4.3. Any change of grease type should be avoided if possible.

For normal operating conditions in vibratory machinery, we recommend lithium soap greases with EP (extreme pressure) and anti-corrosion additives corresponding to penetration class 2. The minimum requirements described in DIN 51 825 are not sufficient for this application. Instead, the suitability of greases for use in the rolling bearing must be demonstrated as is the case with, for example, the FAG greases Arcanol MULTITOP and LOAD400.

In applications with higher operating temperatures, for example in screens for hot materials or where the bearings may in special cases undergo considerable heating by the material in the box, special greases with high thermal stability should be used.

The base oil viscosity required is dependent on the operating conditions. The aim should be to achieve a viscosity ratio $\kappa = \nu/\nu_1 \geq 2$, where ν is the operating viscosity and ν_1 is the reference viscosity, see also Catalogue HR 1, Rolling Bearings. When rolling bearings are fitted, the internal cavities of the bearings must be filled with grease to *Table 14*. During the startup phase, the grease will be distributed in the bearing and partly (aprox. 30 % of the grease quantity/bearing) fill the housing cavities V_G next to the bearing. These cavities may be filled with grease to a maximum of 50 %, once the grease distribution in the bearing is completed.

Note:

Grease quantity housing cavities:

$$H_G = (0,5 \cdot V_G) \cdot \rho \\ - 0,3 \text{ grease quantity/bearing}$$

with a grease density
(for most greases) of $\rho = 0,9 \text{ g/cm}^3$

This prevents excessive working and the associated temperature development. The grease in the housing cavities acts as a reservoir and contributes to a longer operating life in accordance with the operating and the mounting conditions.

It is recommended that relubrication should be carried out via the lubrication groove and the lubrication holes that are present as

standard in the outer ring of all FAG special spherical roller bearings.

This ensures uniform supply of lubricant to both rows of rollers.

Where rolling bearings are relubricated from the side, the distance between the housing wall and the end face of the bearing should be as small as possible so that the grease can reach the bearing interior quickly and without losses. The grease outlet hole should be located on the opposite side of the bearing.

In bearing arrangements for vibratory machinery, it is advisable to relubricate the bearings with small quantities of grease at short intervals.

The table in *Figure 14* gives relubrication quantities as a function of bearing size and speed. These relubrication quantities relate to a relubrication interval of 50 operating hours and normal operating temperatures.

If continuous relubrication is carried out by means of a central lubricant supply system, the grease quantity m_1 required per hour per bearing can be determined using the formula

$$m_1 = 0,00004 \cdot D \cdot B$$

where

m_1 = required grease quantity [g/h]

D = bearing outside diameter [mm]

B = bearing width [mm]

The labyrinth seals should be relubricated once per week, or more frequently if operating conditions are unfavourable (heavy exposure to dust, moisture, high operating temperature). The grease should be the same as that used in the rolling bearings.

Lubrication of bearings

Grease lubrication

14: Initial greasing and relubrication quantities in g for spherical roller bearings 223 in vibratory machinery (relubrication interval: 50 operating hours)

Bore code	Initial grease quantity	Relubrication quantity for speed min ⁻¹																	
		500	600	700	800	900	1000	1200	1400	1600	1800	2000	2200	2400	2600	2800	3000	3200	
08	16	5	5	5	5	5	5	5	5	5	5	5	5	5	5	5	5	5	
09	22	5	5	5	5	5	5	5	5	5	5	5	5	5	5	5	5	10	10
10	27	5	5	5	5	5	5	5	5	5	5	5	5	10	10	10	10	10	15
11	43	5	5	5	5	5	5	5	5	5	5	10	10	10	10	15	15	20	
12	50	5	5	5	5	5	5	5	5	5	10	10	10	10	15	15			
13	56	5	5	5	5	5	5	5	10	10	10	10	15	15	20				
14	76	5	5	5	5	5	5	10	10	10	15	15	20	25					
15	91	5	5	5	5	5	5	10	10	10	15	20	25						
16	100	5	5	5	10	10	10	10	10	15	20	25							
17	130	5	5	10	10	10	10	10	15	20	25	35							
18	145	10	10	10	10	10	10	15	20	25	30	40							
19	180	10	10	10	10	10	15	15	25	35	45								
20	185	10	10	10	10	15	15	20	30	40									
22	270	10	10	15	15	20	20	30	50	70									
24	330	15	15	20	25	30	35	55	85										
26	420	15	20	20	25	35	40	65											
28	525	20	25	30	35	45	60	100											
30	630	25	30	40	50	65	90												
32	725	25	35	45	60	80	100												
34	870	30	40	55	80	110	140												
36	1000	35	50	65	90	120													
38	1200	45	65	90	130														
40	1400	50	70	100	150														
44	1700	70	105	160															

Lubrication of bearings

Oil lubrication

4.2 Oil lubrication

If the speeds are above the normal range for grease lubrication (i.e. speed parameter $n \cdot d_m > 300\,000 \text{ min}^{-1} \cdot \text{mm}$), oil lubrication must be provided. Oil lubrication may also be necessary if there is heating by external sources or for reasons of maintenance.

For lubrication of bearings, we recommend mineral oils or synthetic oils with EP (extreme pressure) and anti-corrosion additives, see also section 4.3. Good quality multi-grade oils can also be used.

The viscosity ratio $\kappa = v/v_1$ (v = operating viscosity, v_1 = reference viscosity) should be ≥ 2 .

A sufficiently large oil quantity will extend the oil change interval. If the cavities in the housings are not sufficient, the shaft guard tube between the bearings can also be used as an oil reservoir or an additional container can be provided.

The oil change interval is dependent on the contamination and the ageing condition of the oil.

Guide values for the oil quantity and oil change intervals as a function of the bearing bore are given in *Figure 15*. For further details, see publication WL 81 115/4 EA "Lubrication of rolling bearings".

We recommend regular oil inspection, since the results of such inspections will allow more precise determination of oil change intervals.

4.2.1 Oil sump lubrication (bath lubrication)

Oil sump lubrication is normally used up to a speed parameter $n \cdot d_m = 300\,000 \text{ min}^{-1} \cdot \text{mm}$; with frequent oil changes, it can be used up to $n \cdot d_m = 500\,000 \text{ min}^{-1} \cdot \text{mm}$. In this lubrication method, the lubricant is conveyed to the rolling contact points by any gears, the imbalance mass or the rolling elements themselves. The oil level in the machine or bearing housing must be sufficiently high that the gears or imbalance masses are dipped in the oil and create a swirling effect. When the bearing is stationary, the lowest roller must be half immersed in the oil, *Figure 16*.

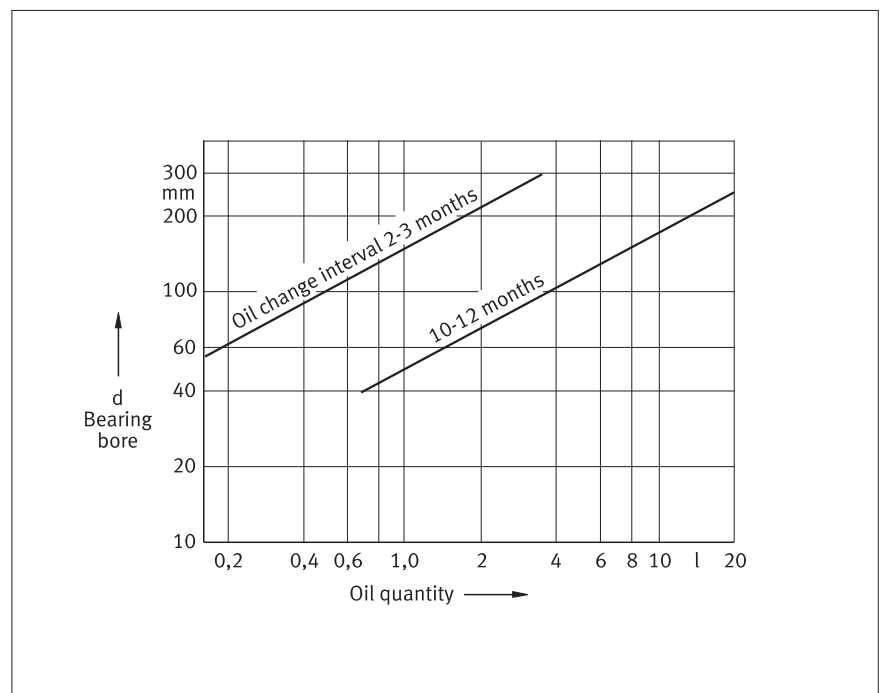

15: Oil quantity and oil change interval as a function of bearing bore diameter

Lubrication of bearings

Oil lubrication

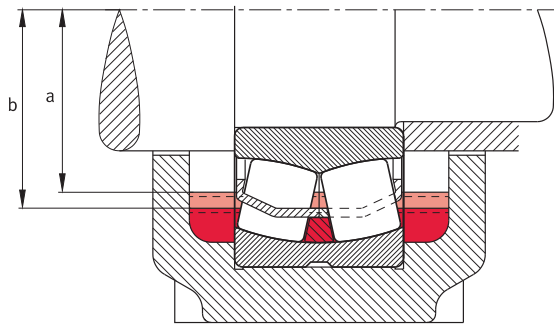

a is the normal oil level
b is the lowest oil level

Bore code	Bearing series 223	
	a mm	b
08	31	34
09	35	38
10	39	42
11	42	46
12	46	50
13	50	54
14	54	59
15	58	62
16	62	67
17	66	71
18	69	74
19	72	78
20	78	84
22	86	94
24	93	101
26	100	109
28	107	117
30	115	125
32	122	133
34	129	140
36	137	149
38	144	156
40	152	165
44	168	182
48	182	195
52	196	211
56	212	228

16: Determining the oil level at standstill

Lubrication of bearings

Oil lubrication · Recommended lubricants

4.2.2 Recirculating oil lubrication

If the speed parameter is higher than the permissible value for bath lubrication or where special conditions apply (increased heat dissipation required, insufficiently large oil cavities), recirculating oil lubrication must be used. The oil should be fed via the lubrication groove and lubrication holes in the bearing outer ring.

Guide values for normal oil flow rates can be determined from the diagram in *Figure 17*.

In order to prevent oil backing up in the lubrication system, the cross-sections of the unpressurised return ducts must be adapted to the cross-sections of the feed ducts (4 to 5 times larger). In recirculating oil lubrication, it is absolutely essential that a filter is provided for retaining wear particles and contaminants in order to prevent impairment of the bearing operating life. Through evaluation of regular oil inspections, the oil change intervals can be matched more accurately to the operating conditions.

4.3 Recommended lubricants

Greases for vibrating screen bearing arrangements

The quality of FAG Arcanol rolling bearing greases is carefully monitored by means of 100% inspection of every batch.

Greases for normal temperatures:
Arcanol MULTITOP
Arcanol LOAD400
Arcanol LOAD220
Arcanol VIB3

Grease for high temperatures:
Arcanol TEMP120

In the case of greases that have not been subjected to our incoming goods inspection, we cannot make any statements regarding batch fluctuations, formulation changes or production influences.

Oils for vibrating screen bearing arrangements

If oils are to be used for this application, it must be demonstrated that the additives package is effective in the rolling bearing. In principle, it is possible to use mineral oils and synthetic oils, with the exception of silicone oils. It is not advisable to use oils with viscosity index improvement agents.



17: Minimum oil flow rate for spherical roller bearings of series 223 in vibratory machinery

Monitoring of vibrating screens

5 Monitoring of vibrating screens

FAG Industrial Services (F'IS) offers reliable monitoring systems that can also be used under very aggressive environmental conditions.

With headquarters in Herzogenrath, near Aachen, F'IS is an independent company that manages all industrial service activities of Schaeffler Group Industrial for both the FAG and INA brands.

F'IS is an independent Full Service Supplier in the field of maintenance and quality assurance: from mounting, through plant monitoring to the introduction and implementation of preventive maintenance activities.

A wide range of mounting and alignment tools, measuring instruments and lubricants, as well as training courses makes maintenance work easier and work processes more efficient. Based on many years' experience and qualified experts, F'IS is the competent partner for customer-oriented solutions relating to the life cycle of rolling bearings.

Special monitoring systems for vibrating screens detect machinery damage at a very early stage. Since the alarm is raised at an early stage, they help to prevent unplanned downtime. On the other hand, operating companies can be remotely informed.

By monitoring the vibrating screens, the following system conditions, for example, can be identified:

- bearing damage
- loose parts
- broken springs
- overloads
- impact/contact

For further information on F'IS services, please look under www.fis-services.com, or send an e-mail to info@fis-services.com.

You will then receive a proposal, matched to your application and requirements.



FAG special spherical roller bearings for vibratory machinery

With cylindrical bore, series 223...-E1-T41A(D)

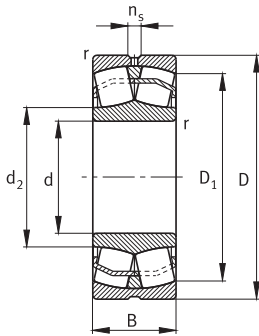

6.1 FAG special spherical roller bearings for vibratory machinery, with cylindrical bore, series 223...-E1-T41A(D)

Shaft	Dimensions							Basic load rating dyn. C_r	Fatigue limit load stat. C_{0r}	Fatigue limit load C_{ur}	Limiting speed n_G	Reference speed n_B	Designation Bearing FAG	Mass m \approx kg
	d	D	B	r	n_s	D_1	d_2							
	mm							kN			min ⁻¹			
40	40	90	33	1,5	4,8	76	52,4	156	149	13,1	7 500	5 500	22308-E1-T41A	1,05
45	45	100	36	1,5	6,5	84,7	58,9	187	183	16,1	6 700	5 000	22309-E1-T41A	1,39
50	50	110	40	2	6,5	92,6	63	229	223	20,3	6 000	4 800	22310-E1-T41A	1,9
55	55	120	43	2	6,5	101,4	68,9	265	260	23,9	5 600	4 500	22311-E1-T41A	2,27
60	60	130	46	2,1	6,5	110,1	74,8	310	310	28	5 000	4 200	22312-E1-T41A	2,89
65	65	140	48	2,1	9,5	119,3	83,2	350	365	32,5	4 800	3 800	22313-E1-T41A	3,57
70	70	150	51	2,1	9,5	128	86,7	390	390	36,5	4 500	3 700	22314-E1-T41A	4,21
75	75	160	55	2,1	9,5	136,3	92,4	445	450	40,5	4 300	3 550	22315-E1-T41A	5,18
80	80	170	58	2,1	9,5	145,1	98,3	495	510	45	4 300	3 400	22316-E1-T41A	6,27
85	85	180	60	3	9,5	154,2	104,4	540	560	50	4 000	3 200	22317-E1-T41D	7,06
90	90	190	64	3	12,2	162,5	110,2	610	630	55	3 600	3 000	22318-E1-T41D	8,51
95	95	200	67	3	12,2	171,2	116	670	700	60	3 000	2 800	22319-E1-T41D	9,69
100	100	215	73	3	12,2	184,7	130,2	810	920	75	3 000	2 380	22320-E1-T41D	12,8
110	110	240	80	3	15	204,9	143,1	950	1 070	91	2 600	2 130	22322-E1-T41D	17,7
120	120	260	86	3	15	222,4	150,8	1 080	1 170	103	2 600	2 000	22324-E1-T41D	22,5
130	130	280	93	4	17,7	239,5	162,2	1 250	1 370	117	2 400	1 820	22326-E1-T41D	28
140	140	300	102	4	17,7	255,7	173,5	1 460	1 630	132	2 200	1 660	22328-E1-T41D	35,1
150	150	320	108	4	17,7	273,2	185,3	1 640	1 850	148	2 000	1 520	22330-E1-T41D	42,2

All spherical roller bearings of series 223...-E1-T41A(D) are X-life designs and are also available with tapered bore. The JPA cage is standard with these bearings and therefore not indicated.

FAG special spherical roller bearings for vibratory machinery

With cylindrical bore, series 223...-E1-JPA-T41A

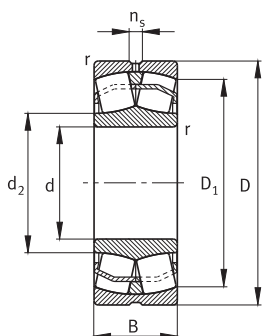

6.2 FAG special spherical roller bearings for vibratory machinery, with cylindrical bore, series 223...-E1-JPA-T41A

Shaft	Dimensions						Basic load rating		Fatigue limit load	Limiting speed	Reference speed	Designation	Mass
	d	D	B	r	ns	D ₁	C _r	C _{0r}	C _{ur}	n _G	n _B	Bearing	m
	mm						kN			min ⁻¹		FAG	≈ kg
160	160	340	114	4	17,7	286,7	1 680	1 990	158	2 100	1 460	22332-E1-JPA-T41A	52,7
170	170	360	120	4	17,7	303,7	1 870	2 220	174	2 100	1 350	22334-E1-JPA-T41A	59,5
180	180	380	126	4	23,5	320,8	2 060	2 460	191	1 960	1 250	22336-E1-JPA-T41A	72,2
190	190	400	132	5	23,5	338	2 260	2 700	208	1 820	1 170	22338-E1-JPA-T41A	81
200	200	420	138	5	23,5	354,9	2 440	2 950	226	1 820	1 100	22340-E1-JPA-T41A	93,5
220	220	460	145	5	23,5	391,9	2 800	3 400	265	1 680	970	22344-E1-JPA-T41A	120

All spherical roller bearings of series 223...-E1-JPA-T41A are X-life designs and are also available with tapered bore. In these bearings, the JPA cage is indicated, since it is not standard.

We can by agreement supply special spherical roller bearings 223...-A-MA-T41A, see Catalogue HR 1, Rolling Bearings.

Query for bearing calculation

7 Query for bearing calculation

(drawing included: yes / no)

Type: Circular screen Linear screen Eccentric screen

The relevant schematics are indicated on pages 7 to 10.

**Load spectrum/
Design data:**

1. Masses [kg]	Screen box m	_____
	Counterweights (exciter) m_1	_____
2. Geometry [m]	Vibration radius r	_____
	Exciter centre of gravity/bearing axis R	_____
3. Speed [min^{-1}]	Operating speed n	_____
4. Operating life	Hours per day	_____
	One-shift or multi-shift operation	_____
5. Life [h]	Minimum life required	_____

**Bearing position/
Mounting data:**

1. Mounting location	A. Non-locating bearing <input type="checkbox"/>	B. Locating bearing <input type="checkbox"/>
	C. Floating bearing arrangement <input type="checkbox"/>	
2. Bearing seat	cylindrical <input type="checkbox"/>	conical <input type="checkbox"/>
3. Number of rolling bearings z	_____	
4. Bearing seating diameter [mm]	Shaft _____	Fit _____
	Housing _____	Fit _____
5. Other dimensions [mm]	Max. diameter	_____
	Min. diameter	_____
	Width	_____

Environmental influence:

Ambient temperature [$^{\circ}\text{C}$]	_____		
Material in box (screen for hot materials) [$^{\circ}\text{C}$]	_____		
Operating temperature [$^{\circ}\text{C}$]	_____		
Moisture [%]	_____		
Dust	Severe <input type="checkbox"/>	Moderate <input type="checkbox"/>	Minimum/none <input type="checkbox"/>
Chemical influences	Yes <input type="checkbox"/>	No <input type="checkbox"/>	
Location	Building <input type="checkbox"/>	Outdoors <input type="checkbox"/>	

Lubrication: Grease Oil sump Oil recirculation Oil mist lubrication

Sealing: Labyrinths that can be relubricated with V ring seals
Oil splash rings and oil collector grooves

Other notes: _____

Notes

Notes

Schaeffler Technologies

GmbH & Co. KG

Postfach 1260

97419 Schweinfurt (Germany)

Georg-Schäfer-Straße 30

97421 Schweinfurt (Germany)

Phone +49 9721 91-0

Fax +49 9721 91-3435

E-Mail mining_processing@schaeffler.com

Internet www.fag.com

Every care has been taken to ensure the correctness of the information contained in this publication but no liability can be accepted for any errors or omissions.

We reserve the right to make technical changes.

© Schaeffler Technologies GmbH & Co. KG

Issued: 2011, February

This publication or parts thereof may not be reproduced without our permission.

TPI 197 GB-D